

INSTRUCTION MANUAL



CQB MRP PISTON WEAPON SYSTEM

Questions, or for further information, please contact:

Lewis Machine & Tool

1305 W. 11th St.

Milan, IL 61264

Phone: (309)787-7151

Fax: (309)787-7193

Email: sales@lmtdefense.com

What's different about the Piston Rifle?

There are 3 major components that are different between the piston system and the standard gas tube system; the bolt carrier, barrel assembly, and the buffer. Converting your weapon only involves replacing the parts on the right with those on the left and replacing the standard buffer with a heavier buffer plug. All required components will be in your conversion kit.

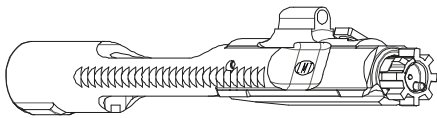

Piston Bolt Carrier Group

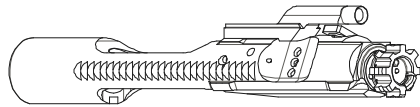

Standard Bolt Carrier Group

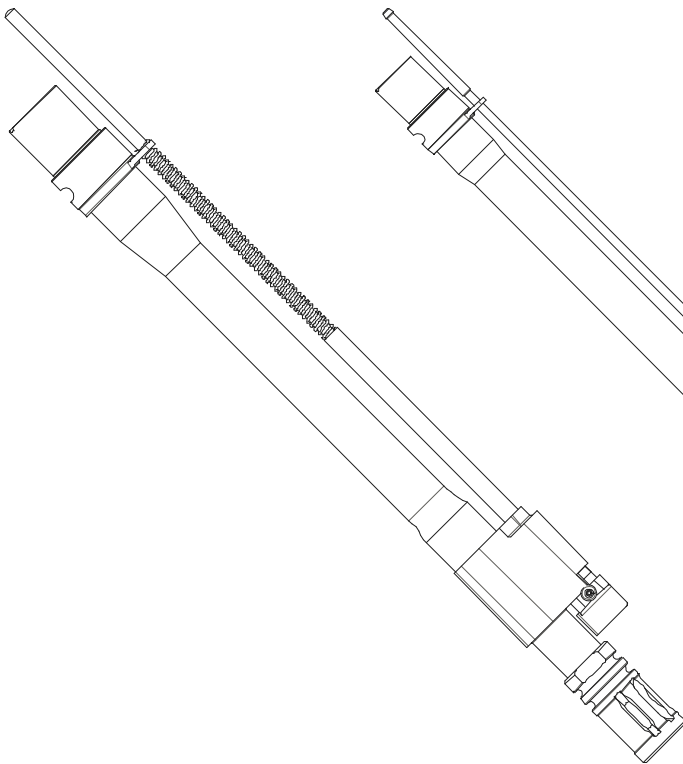

Piston Barrel Assembly

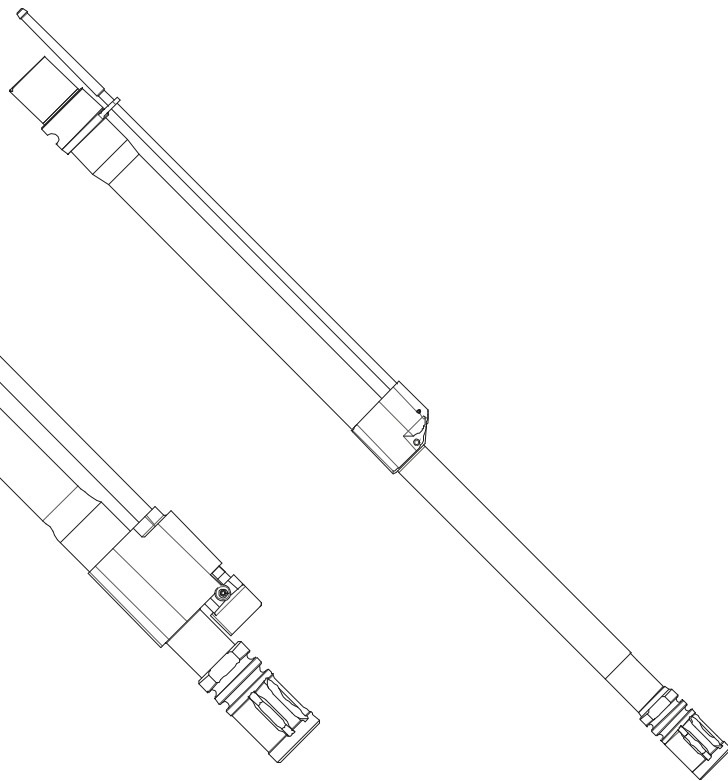

Standard Barrel Assembly

Operation

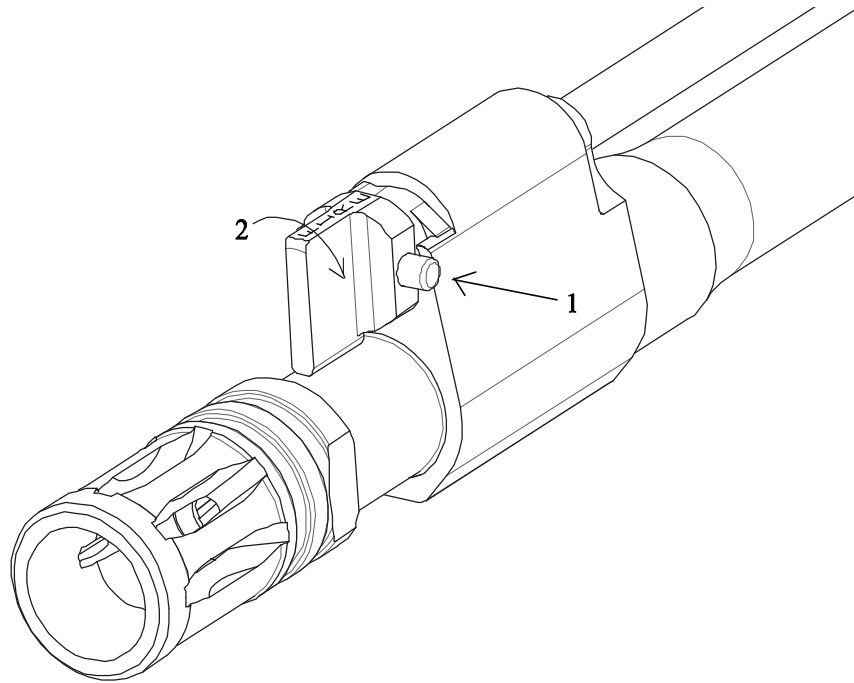

For the piston system to function in a normal cyclical operation, the piston plug must be positioned to match the operator's mission. There are two positions on the piston plug, "FIRE" and "SUPP". These positions represent different weapon operational configurations and must be configured to match. For operational configuration that DOES NOT include a qualified sound suppressor system, the piston must be set so the inscription of "FIRE" is presented to the top so the operator can view it. If the weapon is to be operated in a suppressed mode with a qualified sound suppresser, the piston plug must be set so the inscription of "SUPP" is presented to the top so the operator can view it. To set the piston plug to match the operation configuration, depress the plunger (1) while rotating the plug (2), counterclockwise from the direction of the breech for "FIRE" and clockwise for "SUPP", until the plug is in the position wanted by the operator (approximately 180°).

WARNING: ALWAYS VERIFY AND PRACTICE SAFE WEAPON OPERATION TACTICS PRIOR TO INSPECTION AND HANDLING OF FIREARMS

Assembly and Disassembly

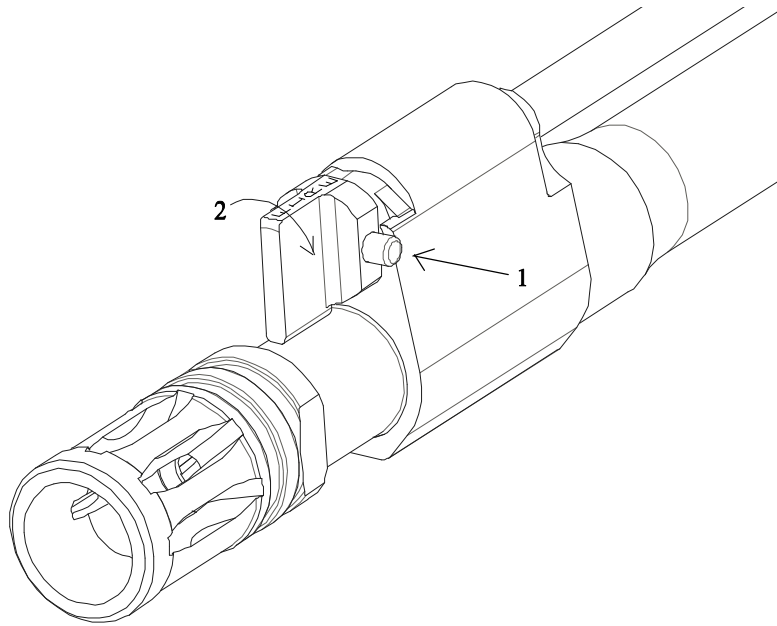

1. To disassemble, depress the plunger (1) while rotating the plug (2) in the direction indicated (counterclockwise from the direction of the breech) until the locking lug is in position to allow the removal of the plug (approximately 90 °).

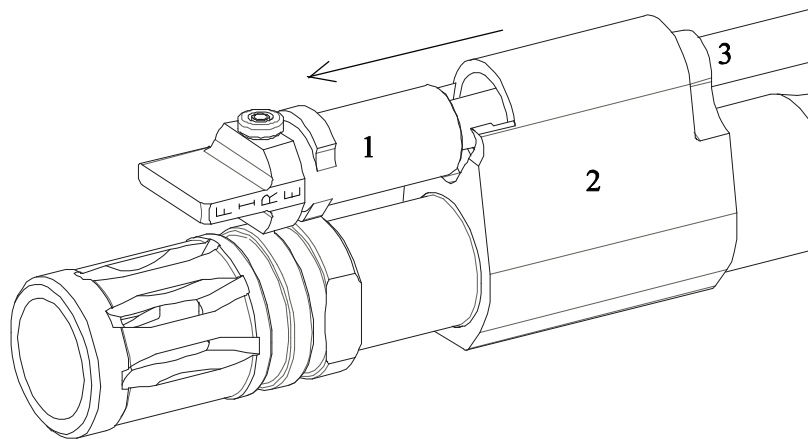

2. Pull the plug (1) from the gas block (2). The piston (3) should come with the plug due to the high-quality fit. However, the piston is easy to remove from the plug with gentle hand pressure.

WARNING: ALWAYS VERIFY AND PRACTICE SAFE WEAPON OPERATION TACTICS PRIOR TO INSPECTION AND HANDLING OF FIREARMS

Cleaning and Maintenance

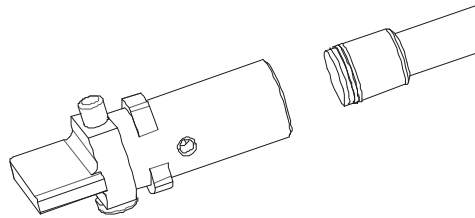

The piston system is designed to work despite carbon buildup and dirt, and concentrate any operational debris near the gas block, away from the user. However, regular cleaning and maintenance will help insure your weapon remains at its optimal performance. All surfaces can be cleaned with CLP. A bore brush may be used to remove buildup from the interior of the gas plug, and drawn across the small gas hole to clean out buildup there. A cloth may be used to wipe down the surfaces of the piston.

It is not advisable to remove the gas rings from the piston.

WARNING: ALWAYS VERIFY AND PRACTICE SAFE WEAPON OPERATION TACTICS PRIOR TO INSPECTION AND HANDLING OF FIREARMS